

WET AREAS – GENERAL INFORMATION

1.0 INSTALLATION OF DIMENSION STONE IN WET AREAS

This chapter of Natural Stone Institute's *Dimension Stone Design Manual* includes general notes and references that apply to the installation of natural stone in wet areas (urinal, toilet and shower partitions, slab and tile showers, steam rooms and steam showers). This chapter should be used in conjunction with chapters 13 and 14, Horizontal and Vertical Installation, respectively.

1.1 Installation Methods. There are several methods by which stone partitions and showers can be installed.¹ Consideration should be given to the various features of each method in making a selection for a specific installation. For more information about installation methods, see the detail drawings at the end of the chapter.

1.2 Labor Assignment. In most regions of the United States, the labor body responsible for installing a stone product will change pending if the stone product is a tile or a cut-to-size product. Labor jurisdiction practices vary regionally and locally, so research is encouraged to ascertain the labor group assigned to the field installation of a given product.

2.0 DESIGN CRITERIA

2.1 Oil-based putty and plumbing sealants should never be used in contact with stone.

2.2 Sound Stones. Only sound stones, free of any cracks, defects, geological flaws, and voids should be used. Variations in natural

products are acceptable. Moisture sensitive stones should not be used in wet areas.

2.2.1 Avoid use of stones that are flawed. Moisture can travel through the flaw to the back face of the stone. Do not use Marble Soundness Classifications “C” or “D” stones, or stones that have adhered fiberglass mesh reinforcement.

2.2.2 Steam Showers. Soundness Classifications C and D marbles used in steam showers and around whirlpool tubs have a tendency to lose their fillings due to moisture, heat, and vibration. Stone tile with adhered fiberglass mesh reinforcement on their back surfaces are not to be used for steam shower applications.

2.2.3 Mesh Backing. Producers frequently apply fiber mesh reinforcement to the back surfaces of stone tiles and slabs to reduce breakage and also increase safety when handling large slabs. Caution should be used when handling these stones. Mesh and resin backing require special consideration when adhesives are chosen. Confirm compatibility of adhesive prior to setting units of this type. Slabs with mesh backing should not be used in free standing vertical applications.

2.3 Anchors. An alternate system that may be used is non-staining, corrosion-resistant dowels, pins, and wire anchors in lieu of standard commercial hardware. The design of these systems must provide for the transfer of loads from the stone through the anchor to the building structure.

2.4 White portland cement is recommended for most light-colored natural stone. White portland cement with a low alkali content is recommended for limestone.

¹ Natural Stone Institute endorses the use of a partial list of details published by the Tile Council of North America. For additional installation information, see

the “Natural Stone Tile Installation Methods” section in the current edition of the *TCNA Handbook for Ceramic, Glass, and Stone Tile Installation*.

2.5 Use cement backer board instead of water-resistant drywall board (green board). Drywall will degrade and the paper on it will become a food source for mold and mildew when subjected to moisture. Do not use “green board” or any gypsum-based product unless a waterproof membrane completely protects the surface from moisture infiltration.

2.6 Positive water movement. All horizontal surfaces (e.g., seats, sills, curbs, etc.) must slope toward drain or toward other surfaces sloped toward a drain.

2.7 Geographic Methods. Some installation methods and materials are not recognized and may not be suitable in some geographic areas because of local trade practices, building codes, climatic conditions, or construction methods. Therefore, while every effort has been made to produce accurate guidelines, they should be used only with the independent approval of technically qualified persons.

3.0 TECHNICAL DATA

3.1 Each stone variety used for stone partitions or shower rooms described in this chapter should conform to the applicable ASTM standard specification and the physical requirements contained therein. The specification for each stone type follows:

3.1.1 Granite: ASTM C615, Standard Specification for Granite Dimension Stone.

3.1.2 Limestone: ASTM C568, Standard Specification for Limestone Dimension Stone.

3.1.3 Marble: ASTM C503, Standard Specification for Marble Dimension Stone, Soundness Classification “A.”

3.1.4 Onyx: No ASTM Standard exists at this time.

3.1.5 Quartz-based Stone: ASTM C616, Standard Specification for Quartz-based Dimension Stone.

3.1.6 Serpentine: ASTM C1526, Standard Specification for Serpentine Dimension Stone.

3.1.7 Slate: ASTM C629, Standard Specification for Slate Dimension Stone.

3.1.8 Soapstone: No ASTM Standard exists at this time.

3.1.9 Travertine: ASTM C1527, Standard Specification for Travertine Dimension Stone.

4.0 TERMINOLOGY

4.1 Definitions.

4.1.1 Hot mop. A substrate employing layers of asphalt applied while hot to create a waterproof barrier.

4.1.2 Cold applied membrane. A liquid applied bonded membrane, impervious to water.

4.1.3 Wet set. Tile installation method prescribed by ANSI A108.1A.

4.1.4 Dry pack. A mortar mixed with inadequate water component to facilitate complete hydration, thereby dependent upon water of opportunity to complete chemical cure. Dry packs are used due to their compatibility and greater ability to allow lateral transfer of water. Dry packs frequently include aggregates coarser than sand.

4.1.5 Positive flow. To move along in the direction of a drain or other planar surfaces sloped towards a drain.

4.1.6 Negative flow. To move along in the direction away from a drain or other planar surfaces sloped towards a drain.

4.1.7 Sheet applied bonded membrane. A waterproof membrane providing a barrier to positive liquid migration per ANSI A118.10.

4.1.8 Shower pan (membrane or liner). Water containment sheeting per ASTM D4551 PVC or ASTM D4068 CPE.

WET AREAS – STONE TOILET PARTITIONS

1.0 PRODUCT DESCRIPTION

1.1 Basic Use. Toilet partitions for all building types.

1.2 Fabrication. Stone toilet partitions are precut, predrilled, and prefinished to dimensions specified on the shop drawings and delivered to the job site ready to install. Certain job conditions make it necessary to perform some fabrication steps at the job site.

1.4 Types. Partitions may be designed as floor-supported or ceiling-suspended.

1.5 Finishes. Polished finish is most common due to ease of maintenance. See chapter 3, Stone Selection, for other commonly available finishes.

1.6 Colors. Some of the commercially available varieties are unsuitable due to reduced soundness of the material or susceptibility to acid attack.

1.7 Sizes. Stone size is limited by the stone deposit and quarrying method of the selected stone and design requirements of the specific project. Appropriate stone thickness will be determined by many factors including soundness of the stone, anchorage capacity and placement, span between supporting members, etc.

1.8 Technical Information. Every construction condition requires engineering based on specific factors for each project—panel weight, backup material, stone mechanical and physical properties, etc. The most stringent code documents always take precedence. Contact the engineer or manufacturer of each anchoring system for its particular technical information and engineering formulas.

1.8.1 The deflection of the material under maximum anticipated load shall not exceed $L/720$.

2.0 INSTALLATION

2.1 Preparatory Work. A solid substrate and a structurally adequate plumbing wall should be provided for proper installation.

2.2 Methods. Partitions are assembled using corrosion resistant hardware. Ceiling-suspended units are fastened to structural steel supports in the ceiling. Ceiling-suspended units may require a metal spline. Floor-supported units require concrete floor construction to secure anchor bolts. Anchorage methods are to comply with applicable codes.

2.2.1 All joints are filled with non-staining sealants or grout. Where so specified, joints requiring sealant shall be first filled with an approved rope backer rod. The backer rod shall be installed to a depth that provides optimum sealant profile after tooling.

2.3 General Precautions. During construction, the General Contractor shall protect all stone from staining or damage.

2.4 The ceiling channel to which the stile should be attached shall be furnished and installed by others.

2.5 Unless otherwise noted, channels, head rails, splines, pilasters, threaded pipe and other fittings are to be supplied by others.

WET AREAS – STONE URINAL PARTITIONS

1.0 PRODUCT DESCRIPTION

1.1 Basic Use. Urinal partitions (or as junior toilet partitions where doors are not desired) for all building types.

1.2 Fabrication. Stone urinal partitions are precut, predrilled, and prefinished to dimensions specified on the shop drawings and are delivered to the job site ready to install. For certain job conditions it is preferable to finish the stone at the job site.

1.3 Types. Partitions may be designed as wall hung or floor-supported (with or without overhead brace).

1.4 Finishes. Polished finish is most common due to ease of maintenance. See chapter 3, Stone Selection, for other commonly available finishes.

1.5 Colors. Some of the commercially available varieties are unsuitable due to reduced soundness of the material or susceptibility to acid attack.

1.6 Sizes. Stone size is limited by the stone deposit and quarrying method of the selected stone and the design requirements of the specific project. Appropriate stone thickness will be determined by many factors including soundness of the stone, anchorage capacity and placement, span between supporting members, etc.

1.7 Technical Information. Every construction condition requires engineering based on specific factors for each project—panel weight, backup material, stone physical and mechanical properties, etc. The most stringent code documents always take precedence. Contact the engineer or manufacturer of each anchoring system for its

particular technical information and engineering formulas.

1.7.1 The deflection of the material under maximum anticipated load shall not exceed $L/720$.

2.0 INSTALLATION

2.1 Preparatory Work. A solid substrate not more than two inches below finish floor and a plumbing wall should be provided for proper installation.

2.2 Methods. Partitions are available floor-supported or ceiling-hung. If ceiling-hung, the General Contractor shall furnish and install the ceiling channel. Unless otherwise noted, channels, head rails, splines, pilasters, threaded pipe and other fittings are to be supplied by others

2.2.1 Partitions are assembled using corrosion resistant hardware. Floor-supported units are set on dowels into the finished floor. Ceiling-hung units are bolted to overhead support. All ceiling-hung units must have a metal spline. Wall-mounted urinal partitions must be attached to the wall at a minimum of three locations.

2.2.2 All joints are filled with non-staining sealants or grout. Where so specified, joints requiring sealant shall be first filled with an approved rope backer rod. The backer rod shall be installed to a depth that provides optimum sealant profile after tooling.

2.3 General Precautions. During construction, the General Contractor shall protect all stone from staining and damage.

WET AREAS – STONE SLAB SHOWER PARTITIONS

1.0 PRODUCT DESCRIPTION

1.1 Basic Use. Shower partitions for all building types.

1.2 Fabrication. Stone shower partitions are precut, predrilled, and prefinished to dimensions specified on the shop drawings and are delivered to the job site ready to install. For certain job conditions it is preferable to finish the stone at the job site.

1.3 Types. Partitions may be designed as wall hung or floor-supported (with or without overhead brace). Partitions are also available as free-standing units with precast terrazzo receptors.

1.4 Finishes. Polished finish is most common due to ease of maintenance. See chapter 3, Stone Selection, for other commonly available finishes.

1.5 Colors. Some of the commercially available varieties are unsuitable due to the lack of soundness of the material or its susceptibility to acid attack.

1.6 Sizes. Stone size is limited by the stone deposit and quarrying method of the selected stone and the design requirements of the specific project. Appropriate stone thickness will be determined by many factors including soundness of the stone, anchorage capacity and placement, span between supporting members, etc.

1.7 Technical Information. Every construction condition requires engineering based on specific factors for each project—panel weight, backup material, stone physical and mechanical properties, etc. The most stringent code documents always take precedence. Contact the engineer or

manufacturer of each anchoring system for its particular technical information and engineering formulas.

1.7.1 The deflection of the material under maximum anticipated load shall not exceed $L/720$.

2.0 INSTALLATION

2.1 Preparatory Work. A solid substrate and a plumbing wall should be provided for proper installation.

2.1.1 Waterproofing (ANSI A118.10) is typically the responsibility of other trades prior to installation of stone. Shower pan or waterproof membrane (ANSI A118.10) must be installed to turn up vertical wall surface at least 3" (75 mm) above the finished surface of the shower curb. The integrity of the waterproof membrane of the floor up to the curb height should be verified by the contractor before commencing work by flood test per building and plumbing code requirements per ASTM D5957, "Standard Guide for Flood Testing Horizontal Waterproofing Installations." Test shower pan or waterproof membrane and drainage fitting for leaks before beginning stone work.

2.1.2 Shower pan or moisture proofing must be pre-sloped at a minimum pitch of $\frac{1}{4}$ " per foot (20 mm per m) to the weep holes of the shower drain assembly. Surround the drain with pea gravel or other weep protection to prevent mortar from blocking weep holes.

2.1.3 Partitions are assembled using corrosion resistant hardware. All joints are sealed with non-staining sealants or grout. Where so specified, joints requiring sealant shall be first filled with an approved rope backer rod. The backer rod shall be installed to a depth that provides optimum sealant profile after tooling.

2.2 Methods. Stone shower partitions are to be installed to allow service or replacement of the partition without damaging adjacent finished surfaces. Stone shower partitions can be installed by one of the following methods:

2.2.1 Free-standing units. Partitions are assembled using corrosion resistant hardware. All joints are filled with non-staining sealants or grout.

2.2.2 Floor-supported units. Partitions are to be set on top of substrate. Floor-supported units are set on dowels into the finished floor.

2.3 General Precautions. During construction, the General Contractor shall protect all stone from staining and damage.

NOTES:

WET AREAS – STONE SLAB RESIDENTIAL SHOWERS, STEAM ROOMS, AND STEAM SHOWERS

1.0 PRODUCT DESCRIPTION

1.1 Basic Use. Shower stalls, steam rooms, and steam showers for residential use.

1.2 Fabrication. Parts are precut and prefinished to dimensions specified on the shop drawings and are delivered to the job site ready to install. For certain job conditions it is preferable to finish the stone at the job site.

1.3 Limitations. Only sound stone varieties should be used. Marble selection is limited to Soundness Classifications “A” and “B”.

1.4 Finishes. Polished finish is most common due to ease of maintenance. See chapter 3, Stone Selection, for other commonly available finishes.

1.5 Colors. Some of the commercially available varieties are unsuitable due to the lack of soundness of the material or its susceptibility to acid attack.

1.6 Sizes. Stone size is limited by the stone deposit and quarrying method of the selected stone and the design requirements of the specific project. Appropriate stone thickness will be determined by many factors including soundness of the stone, anchorage capacity and placement, span between supporting members, etc.

1.7 Technical Information. Every construction condition requires engineering based on specific factors for each project—panel weight, backup material, stone physical and mechanical properties, etc. The most stringent code documents always take precedence. Contact the engineer or manufacturer of each anchoring system for its

particular technical information and engineering formulas.

1.7.1 Construction of walls and partitions should be designed to maximum deflection of $L/720$ for conditions utilizing thick-set or thin-set mortar installation methods.

2.0 INSTALLATION – SLAB SHOWER STALLS

2.1 Preparatory Work. Shower pan or waterproof membrane (ANSI A118.10) must be installed to turn up vertical wall surface at least 3" (75 mm) above the finished surface of the shower curb. The integrity of the waterproof membrane of the floor up to the curb height should be verified by the contractor before commencing work by flood test per building and plumbing code requirements per ASTM D5957, “Standard Guide for Flood Testing Horizontal Waterproofing Installations.” Test shower pan or waterproof membrane and drainage fitting for leaks before beginning stone work.

2.1.1 Shower pan or waterproofing must be pre-sloped to a minimum pitch of $\frac{1}{4}$ " per foot (20 mm per m) to the weep holes of the shower drain. Surround the drain with pea gravel or other weep protection to prevent mortar from blocking weep holes.

2.2 Method. Shower stall floor should be installed in a dry-pack mortar bed consisting of one part portland cement to four to five parts sand, 100% coverage of mortar bed material between floor and substrate is recommended. Moisture must be able to freely migrate laterally through the mortar bed and discharge via the weep holes in the shower drain assembly.

2.3 Stone wall panels are set firmly against masonry walls or waterproofed surfaces.

2.4 Joint width can be maintained by using plastic shims. Joints should be at least

1/16" (1.5 mm) wide and pointed with white cement, grout, or non-staining sealant. Joint width must be specified.

2.5 Anchors that contact the stone should be corrosion resistant metal (stainless steel, copper, bronze, brass, aluminum) and should be securely attached to the structure and the stone.

2.6 Exposed stone edges must be gauged to the precise thickness specified.

2.7 Face Sealing. Stone residential shower stalls may be sealed or unsealed.

2.7.1 If sealed, follow Manufacturer's written recommendations for cleaning, stripping, and resealing. The chemicals used should contain no acids or harshly alkaline ingredients. Both types destroy the polished finishes on some stone varieties.

2.7.2 Sealing does not eliminate the need for frequent cleaning of the wall or floor surfaces. A neutral detergent (pH of 7) is the recommended cleaning agent.

2.8 Stone Ceilings. For details and information regarding stone ceilings in residential showers, refer to the "Stone Soffits" section of this Manual in Chapter 14, Vertical Surfaces.

2.9 General Precautions. During construction, the General Contractor shall protect all stone from staining and damage.

3.0 INSTALLATION – SLAB STEAM ROOMS AND STEAM SHOWERS

Steam rooms are highly specialized applications. All electrical and plumbing fixtures should be rated for steam rooms. Steam rooms for continuous use require a membrane (ANSI A118.10) with a water vapor permeance (perm rating) of 0.5 or less.

Professional design and installation are critical to avoid damage to adjacent material due to vapor migration and heat transfer.

3.1 Waterproofing. A waterproofing membrane (ANSI A118.10) must extend a minimum of 3" above the top of the finished surface of the curb. All backup surfaces must be waterproofed with a membrane authorized by the Manufacturer for steam room applications. All horizontal surfaces shall be pre-sloped to a minimum pitch of ¼" per foot (20 mm per m) toward the shower drain assembly. The integrity of the waterproof membrane on the floor up to the height of the curb should be verified by the contractor before commencing work by flood test per building and plumbing code requirements per ASTM D5957, "Standard Guide for Flood Testing Horizontal Waterproofing Installations."

3.2 Methods. Stone may be installed by using any of the approved methods. Exterior methods must be used in the shower. Avoid use of gypsum board in shower areas.

3.3 Ceilings are to be sloped ½" per foot (40 mm per m) up to 2" per foot (170 mm per m) for textured finishes to bring moisture to the face of the wall opposite the shower head, or the principal wall(s) of the room. For example, consider sloping the ceiling away from the wall including a bench or doorway. Sloping ceiling from the center can minimize rundown on the walls. Large, one-piece shower ceilings should be supported by the shower walls. An additional anchor should be installed at the cutout for the fan or fan/light combination.

3.4 Finished surface must be sloped toward the shower drain assembly at a minimum pitch of ¼" per linear foot (20 mm per m) and a maximum pitch of ½" per linear foot (40 mm per m).

3.5 Grout is to be full stone depth. Cured grout should not be easily penetrated with a pocket knife blade.

3.6 Installation materials must be authorized by the Manufacturer for steam room applications. Water should be potable and free of any staining agents. Stone tiles may be used.

3.7 Stone may be installed using any of the following methods:

3.7.1 A thin-set method on a mortar bed or cementitious backer board for tile only. Setting material suitability may be affected by the size of stone units to be installed. Consult with adhesive manufacturer for specific recommendations.

3.7.2 Mortar bed (wet set) method. The method (ANSI A108.1A) that requires that the stone be set on a mortar bed that is still plastic.

3.7.3 Mechanically anchored. An installation system over a waterproofed backing of scratch coat or cementitious backer board for pieces greater than 2' x 2' (600 x 600 mm). Weep holes should be provided at the base of the cavity or as shown on architectural drawings, to evacuate accumulated condensation from the air space between the back face of the stone and the substrate. Additionally, openings should be provided at the top of the installation to accommodate ventilation of the cavity

3.8 Effects of Steam on Stone and Anchorage. Steam is a catalyst. Many stones contain elements and metallic compounds that will react with steam and form other elements not common to the stone's variety. Color change in background and veining could result, and the stone's structural integrity may be compromised. Use non-corroding hardware in all conditions where in contact with stone.

3.9 Additional Moisture Control. Adhered stone should be solid-set to avoid

moisture at the back face. Weep holes should be provided to evacuate moisture from any voids which may have developed between the back face of the stone and the substrate.

3.10 Provision for Steam Generator. Oversize the diameter of the hole in the stone for the steam pipe a minimum of 1/4" (6 mm). Center the steam line in the hole and use high temperature silicone or insulation to act as a heat barrier between the steam and the stone material.

3.10.1 Install steam shower controller per Manufacturer's installation instructions. When installing on cleft or irregular surfaced stone, ensure control is sealed to wall.

NOTES:

WET AREAS – STONE TILE RESIDENTIAL SHOWERS, STEAM ROOMS, AND STEAM SHOWERS

1.0 PRODUCT DESCRIPTION

1.1 Basic Use. Shower stalls, steam rooms, and steam showers for residential use.

1.2 Fabrication. Parts are precut and pre-finished to dimensions specified on the shop drawings and are delivered to the job site ready to install.

1.3 Limitations. Only sound stone varieties, including Soundness Classification Groups A and B marbles, should be used. Stone tile with adhered fiberglass mesh reinforcement on their back surfaces are not to be used for shower applications. Due to the nature of stone tile production, it can be expected that wide ranges in color and veining will occur. It is unreasonable to expect the Installer to produce specific matching patterns or strict adherence to a specific range of colors from tiles pulled one by one out of a carton unless specific instructions are given and agreed to before the installation is begun.

1.4 Finishes. Polished finish is standard. See chapter 3, Stone Selection, for other commonly available finishes.

1.5 Colors. Most of the commercially available varieties are suitable. However, some varieties are unsuitable due to the reduced soundness of the material or susceptibility to acid attack.

1.6 Sizes. Stone size is limited by the stone deposit and quarrying method of the selected stone and the design requirements of the specific project. Appropriate stone thickness will be determined by many factors including soundness of the stone, anchorage capacity and placement, span between supporting members, etc.

1.7 Technical Information. Every construction condition requires engineering based on specific factors for each project—panel weight, backup material, stone physical and mechanical properties, etc. The most stringent code documents always take precedence. Contact the engineer or manufacturer of each anchoring system for its particular technical information and engineering formulas.

1.7.1 The deflection of the material under maximum anticipated load shall not exceed $L/720$.

1.8 Exposed stone edges must be gauged to the precise thickness specified.

2.0 INSTALLATION – TILE SHOWER STALLS

2.1 Preparatory Work. Shower pan, waterproof membrane (ANSI A118.10), or vapor retarder membrane (ANSI A108.02-3.8) must be specified (see current TCNA B414 STONE for details). Turn shower pan membrane up vertical wall surface at least 3" (75 mm) above the finished surface of the shower curb [6" (150 mm) above floor in showers without curbs]. The integrity of the waterproof membrane up to the height of the curb should be verified by the contractor before commencing work by flood test per building and plumbing code requirements per ASTM D5957, "Standard Guide for Flood Testing Horizontal Waterproofing Installations."

2.2 Method. Shower stall floor should be installed in a dry-packed mortar bed consisting of one part portland cement to four to five parts sand. 100% coverage of mortar bed material between floor and sub-slab is recommended.

2.2.1 Shower pan membrane must be sloped toward the shower drain assembly at a minimum pitch of $\frac{1}{4}$ " per linear foot. Finished surface must be sloped toward the shower

drain assembly at a minimum pitch of ¼" per linear foot (20 mm per m) and a maximum pitch of ½" per linear foot (40 mm per m).

2.2.2 A plumb, properly waterproofed backup wall with a maximum variation of 1/8" in 8'-0" (3mm per 2.5 m) must be provided. Thinset adhesive is spread over the substrate with a notched trowel, and the stone tile is put into place with a slight twisting motion. For all applications, the stone tile shall be back buttered to achieve, as close as practical, 100% adhesive contact between the stone and the backup.

2.3 Joint width can be maintained by using plastic shims. Joints should be at least 1/16" (6.5) wide. Joint width must be specified.

2.4 Movement Joints (Architect must specify type of joint and show location and details on drawings). Movement joints are mandatory according to TCNA EJ171.

2.5 Sealing. Stone tiles installed in residential showers may be sealed or unsealed, according to the Owner's preference.

2.5.1 If sealed, follow Manufacturer's written recommendations for cleaning, stripping, and resealing. The chemicals used should contain no acids or harshly alkaline ingredients. Both types destroy the polished finishes on some stone varieties.

2.5.2 Sealing does not eliminate the need for frequent cleaning of the wall or floor surfaces. A neutral detergent (pH of 7) is the recommended cleaning agent.

2.6 General Precautions. During construction, the General Contractor shall protect all stone from staining and damage.

3.0 INSTALLATION – TILE STEAM ROOMS AND STEAM SHOWERS

Steam rooms are highly specialized applications. All electrical and plumbing fixtures should be rated for steam rooms. Steam rooms for continuous use require a membrane (ANSI A118.10) with a water vapor permeance (perm rating) of 0.5 or less. Professional design and installation are critical to avoid damage to adjacent material due to vapor migration and heat transfer.

3.1 Installation materials must be authorized by the Manufacturer for steam room applications. Water must be free of metals and should be potable.

3.2 Preparatory Work. Shower pan (ANSI A118.10, ASTM D4068 or D4551 and meeting applicable building codes) must be specified (see current TCNA SR613 or SR614 for details). Turn shower pan membrane up vertical wall surface at least 3" (75 mm) above the finished surface of the shower curb [6" (150 mm) above floor in showers without curbs]. The integrity of the waterproof membrane up to the height of the curb should be verified by the contractor before commencing work by flood test per building and plumbing code requirements per ASTM D5957, "Standard Guide for Flood Testing Horizontal Waterproofing Installations."

3.3 Stone tile may be installed using any of the following methods:

3.3.1 Thin-set method on a mortar bed or cementitious backer board.

3.3.2 A full mortar bed. A full mortar bed or wet set method (ANSI A108.1A) that requires that the stone be set on a mortar bed that is still plastic.

3.3.3 Tiles as thin as 3/8" may be used. Reference current edition of TCNA *Handbook for Ceramic, Glass, and Stone Tile Installation* for additional details.

3.4 Effects of Steam on Stone. Steam is a catalyst. Many stones contain elements and

metallic compounds that will react with steam and form other elements not common to the stone's variety. Color change in background and veining could result, and the stone's structural integrity may be compromised. Use non-corroding hardware in all conditions where in contact with stone.

3.5 Moisture Proofing. Stone should be solid-set to avoid creating a moisture collection cavity at the back face.

3.6 Ceilings are to be sloped ½" per foot (40 mm per m) up to 2" per foot (170 mm per m) for textured finishes to bring moisture to the face of the wall opposite the shower head, or the principal wall(s) of the room. For example, consider sloping the ceiling away from the wall including a bench or doorway. Sloping ceiling from the center can minimize rundown on the walls.

3.7 Slope shower pan membrane a minimum of ¼" per foot (20 mm per m) to weep holes in drain.

3.8 Grout is to be full stone depth.

3.9 Provision for Steam Generator. Oversize the diameter of the hole in the stone for the steam pipe a minimum of ¼" (6 mm). Center the steam line in the hole and use high temperature silicone or insulation to act as a heat barrier between the steam and the stone material.

3.9.1 Install steam shower controller per Manufacturer's installation instructions. When installing on cleft or irregular surfaced stone, ensure control is sealed to wall.

WET AREAS – ACCESSORIES AND STONE PENETRATIONS

1.0 ACCESSORIES

1.1 Accessories must meet all applicable building codes and be installed per Manufacture's recommendations.

1.2 Manufacturer's standard design hardware and accessories shall be made of non-corroding materials.

1.3 All built-in seats, sills, curbs, etc., shall be waterproof and installed over a pre-sloped, flashed, waterproof membrane. Finish surface and substrate should have a minimum slope of ¼" per foot (20 mm per m) toward the drain.

1.4 All built-in seats, sills, curbs, etc., must be dimensionally stable when moist and structurally sound.

2.0 PENETRATIONS

2.1 Penetrating the waterproof system or the stone is often necessitated for the installation of recessed niches, all features of niches (e.g., shelves, lights), and corner seats, grab bars, fans or fan/light combinations, etc.

2.2 All openings, cut-outs or protrusions through the waterproofing system should be sealed with a suitable flexible sealant.

2.3 Any opening penetrating the waterproof envelope must be flashed and sealed to become an integral part of the system.

2.4 Any penetrations through the stone shall be made waterproof with a non-staining flexible sealant.

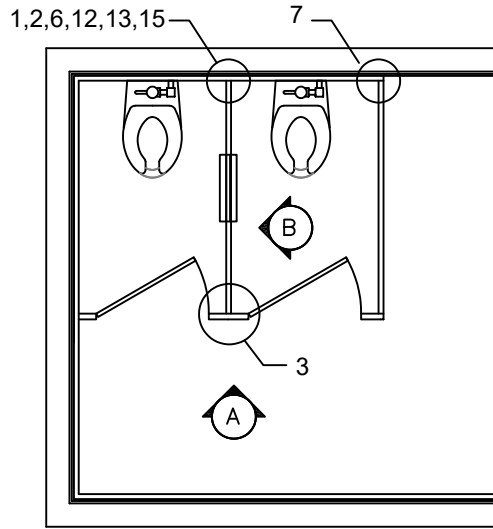

PLAN
TYPICAL LAYOUT

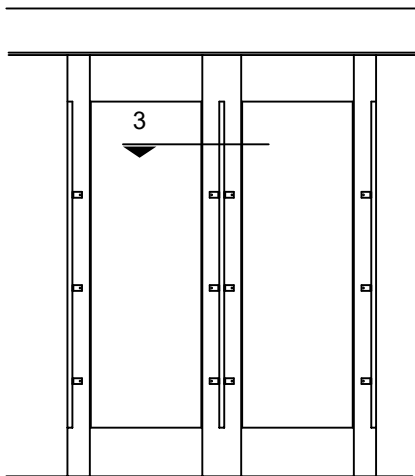

ELEVATION A
HARDWARE MOUNTED

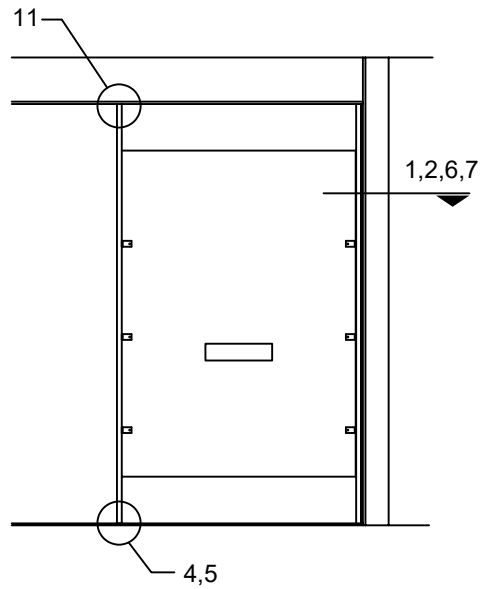

ELEVATION B
HARDWARE MOUNTED

FLOOR SUPPORTED STALL



380 East Lorain Street, Oberlin, OH 44074 USA
www.naturalstoneinstitute.org

REV	DATE
0	MAR 2022

**STONE TOILET PARTITIONS
(FLOOR-SUPPORTED)**

DIMENSION STONE DESIGN MANUAL 2022

DRWG NO: 16-D-1

SCALE:
¼" = 1'-0"

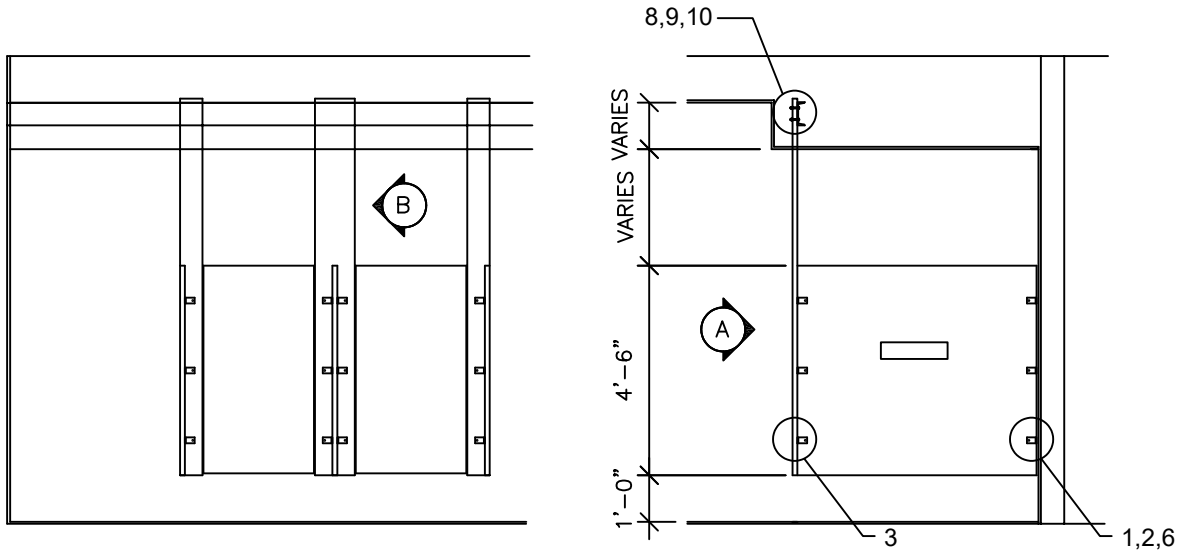

ELEVATION A
HARDWARE MOUNTED

ELEVATION B
HARDWARE MOUNTED

CEILING MOUNTED STALL



380 East Lorain Street, Oberlin, OH 44074 USA
www.naturalstoneinstitute.org

REV	DATE
0	MAR 2022

STONE TOILET PARTITIONS (CEILING-MOUNTED)

DIMENSION STONE DESIGN MANUAL 2022

DRWG NO: 16-D-2

SCALE:
1/4" = 1'-0"

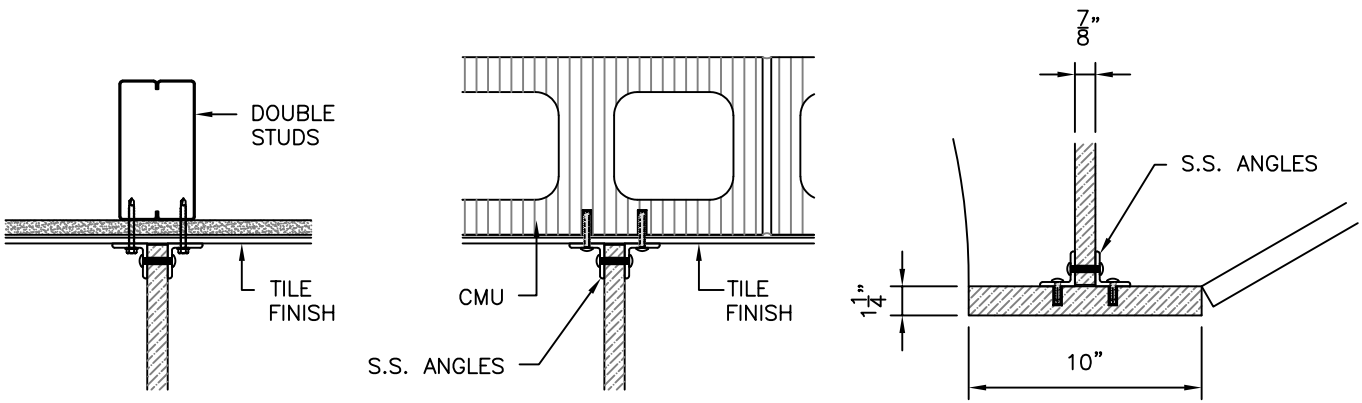

PLAN 1
HARDWARE MOUNTED

PLAN 2
HARDWARE MOUNTED

PLAN 3
HARDWARE MOUNTED

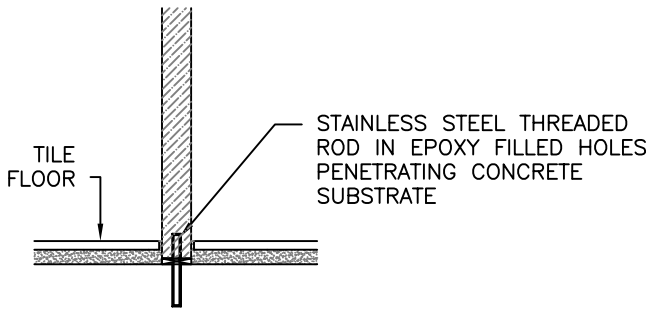

SECTION 4
FLOOR SUPPORTED

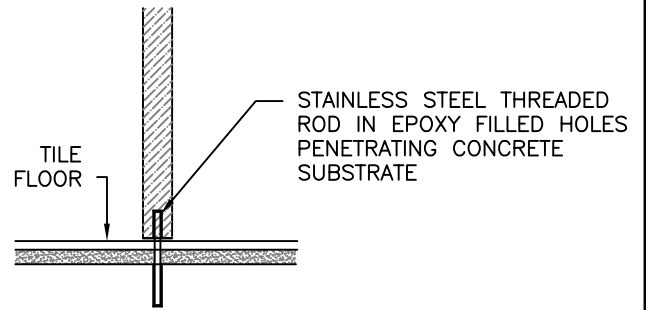

SECTION 5
FLOOR SUPPORTED

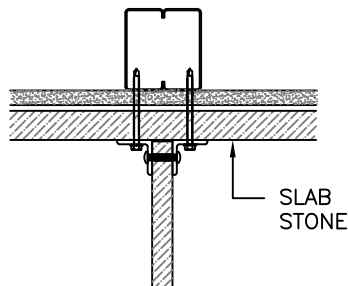

PLAN 6
HARDWARE MOUNTED

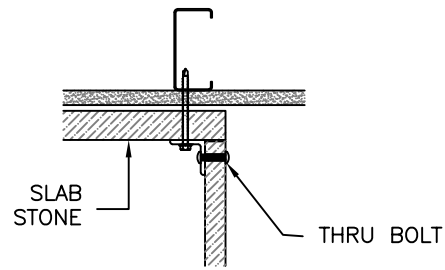

PLAN 7
HARDWARE MOUNTED



380 East Lorain Street, Oberlin, OH 44074 USA
www.naturalstoneinstitute.org

REV	DATE
0	MAR 2022

STONE TOILET PARTITIONS
(FLOOR-SUPPORTED)

DIMENSION STONE DESIGN MANUAL 2022

DRWG NO: 16-D-3

SCALE:
1½" = 1'-0"

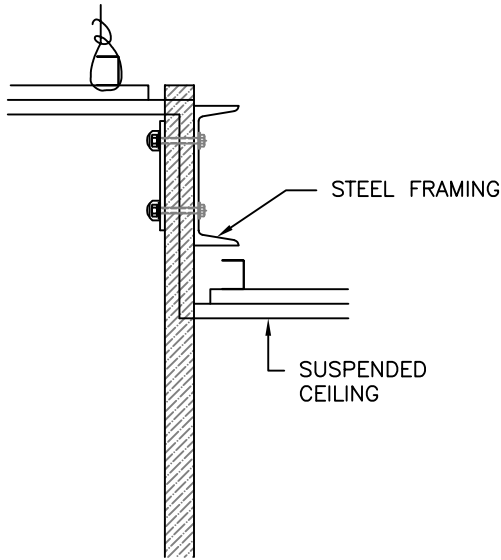

DETAIL 8
CEILING MOUNTED

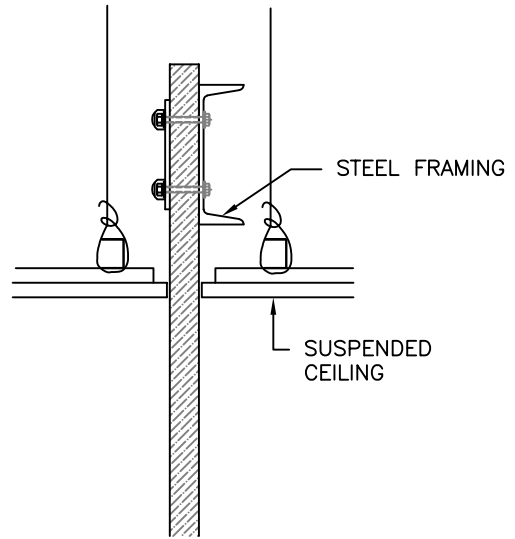

DETAIL 9
CEILING MOUNTED

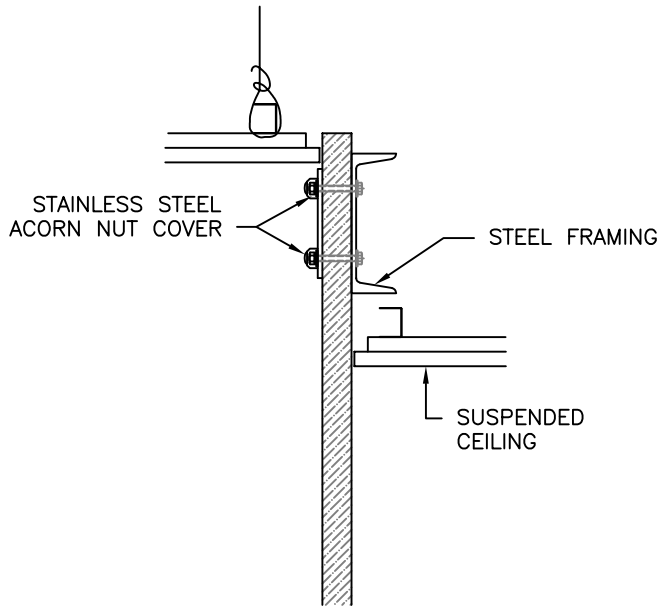

DETAIL 10
CEILING MOUNTED

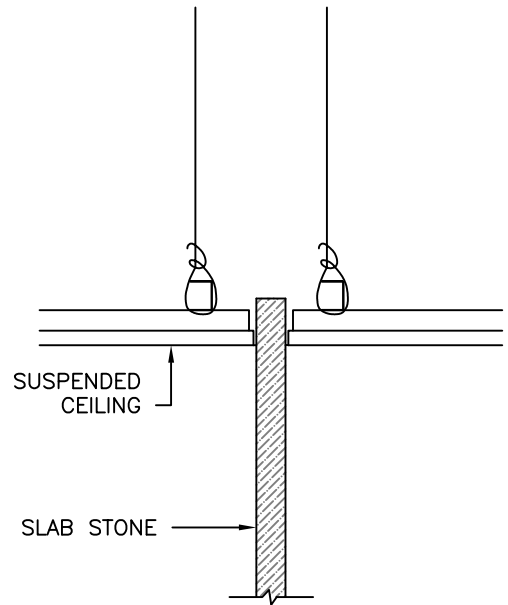

DETAIL 11
FLOOR MOUNTED



NATURAL
STONE
INSTITUTE

380 East Lorain Street, Oberlin, OH 44074 USA
www.naturalstoneinstitute.org

REV	DATE
0	MAR 2022

STONE TOILET PARTITIONS
(CEILING-MOUNTED)

DIMENSION STONE DESIGN MANUAL 2022

DRWG NO: 16-D-4

SCALE:
1½" = 1'-0"

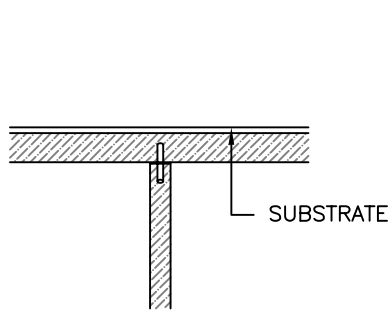

PLAN 12
DOWEL MOUNTED

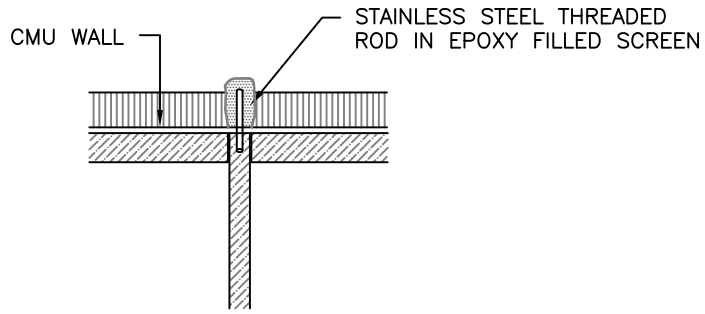

PLAN 13
DOWEL MOUNTED

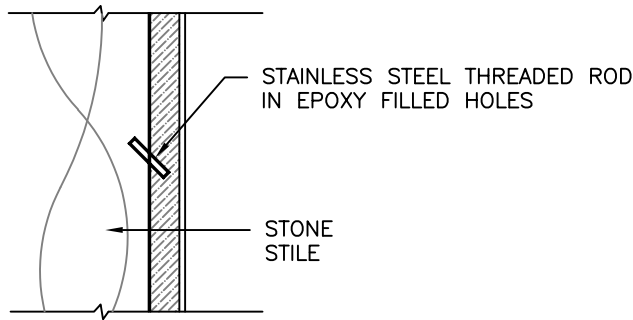

SECTION 14
DOWEL MOUNTED

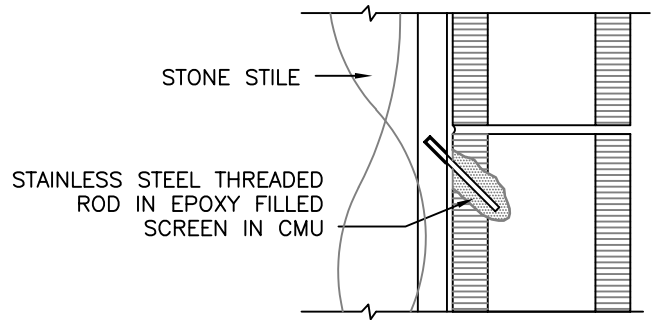

SECTION 15
DOWEL MOUNTED



380 East Lorain Street, Oberlin, OH 44074 USA
www.naturalstoneinstitute.org

REV	DATE
0	MAR 2022

STONE TOILET PARTITIONS
(DOWEL-MOUNTED)

DIMENSION STONE DESIGN MANUAL 2022

DRWG NO: 16-D-5

SCALE:
1½" = 1'-0"

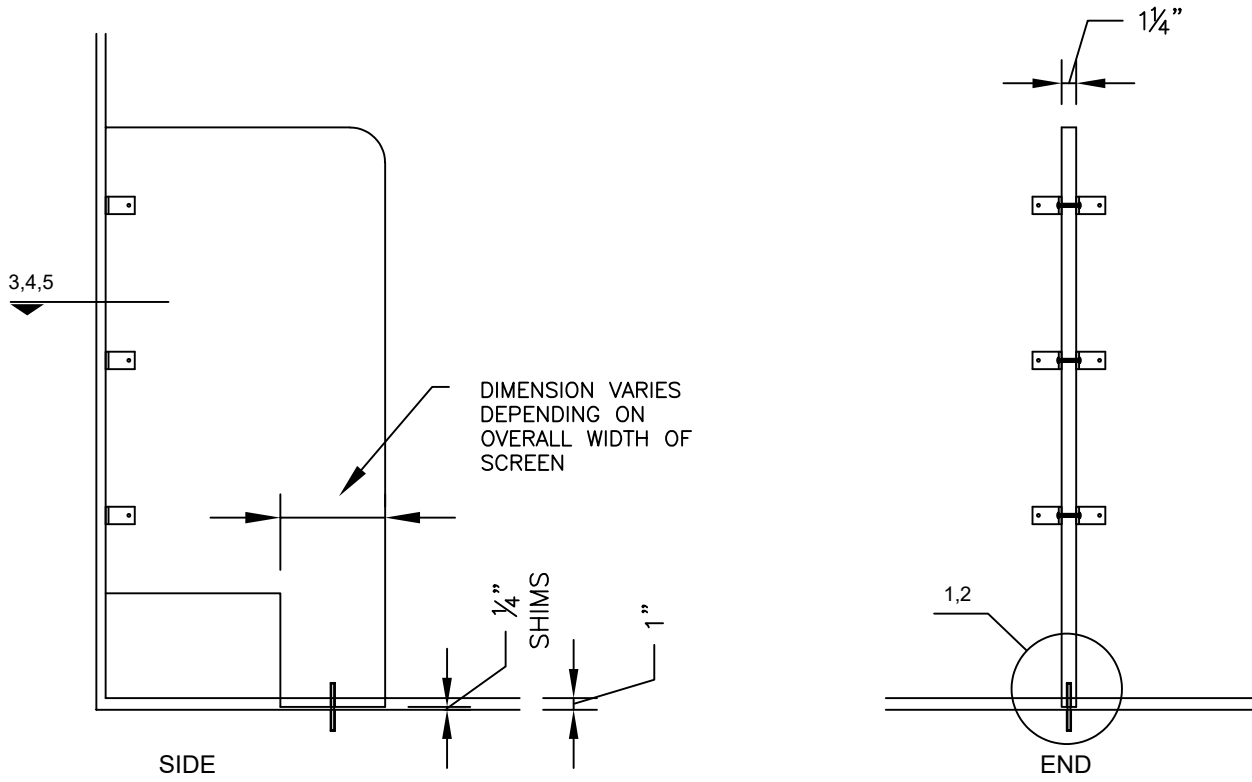

URINAL SCREEN ELEVATIONS - FLOOR SUPPORTED

3/4"=1'-0"

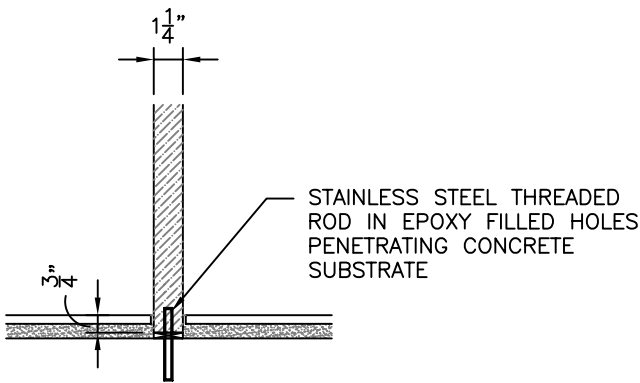

DETAIL 1
LEG PENETRATING FLOOR

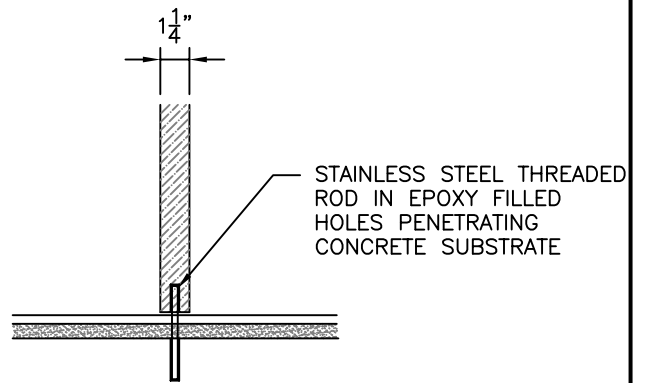

DETAIL 2
LEG RESTING ON FLOOR

1 1/2"=1'-0"



NATURAL
STONE
INSTITUTE

380 East Lorain Street, Oberlin, OH 44074 USA
www.naturalstoneinstitute.org

REV	DATE
0	MAR 2022

STONE URINAL PARTITIONS
(FLOOR-SUPPORTED)

DIMENSION STONE DESIGN MANUAL 2022

DRWG NO: 16-D-6

SCALE:
AS NOTED

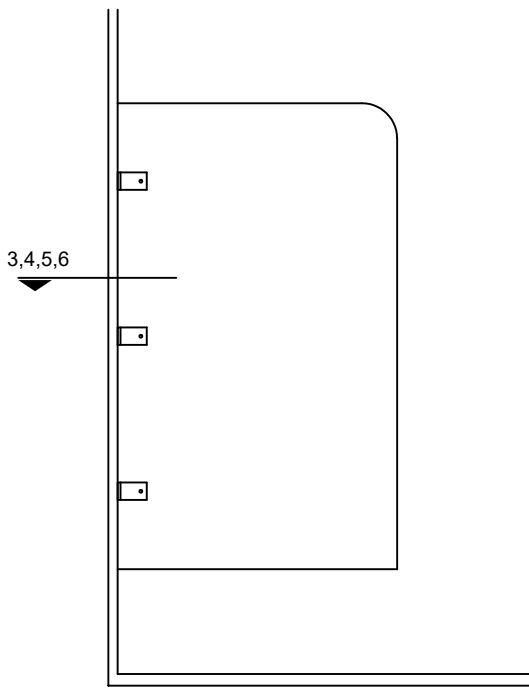

SIDE

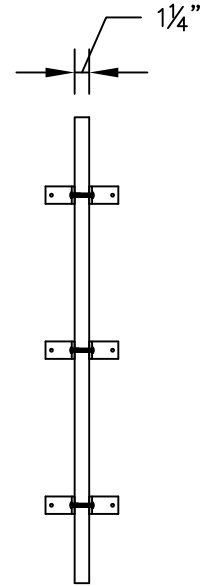

END

URINAL SCREEN ELEVATIONS - WALL MOUNTED

3/4"=1'-0"

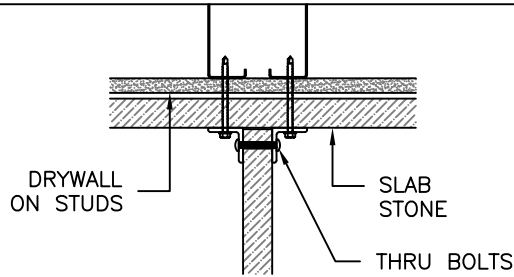

PLAN 3
HARDWARE MOUNTED

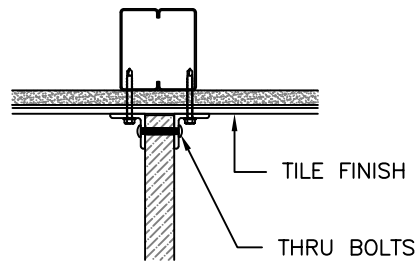

PLAN 4
HARDWARE MOUNTED

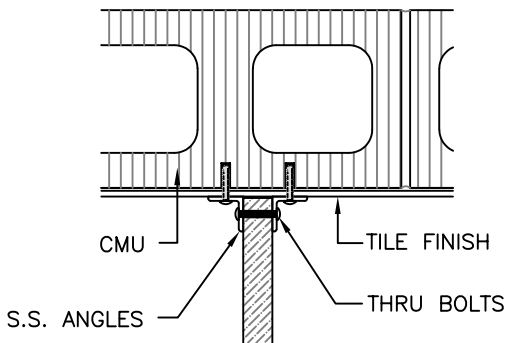

PLAN 5
HARDWARE MOUNTED

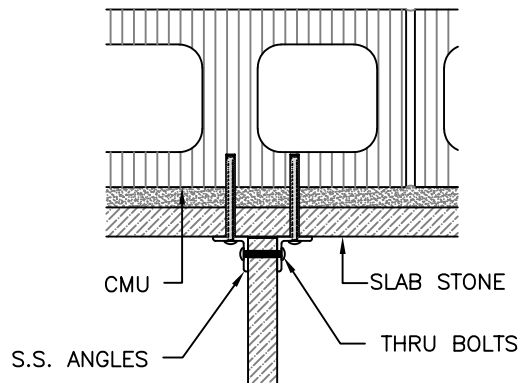

PLAN 6
HARDWARE MOUNTED

1 1/2"=1'-0"



380 East Lorain Street, Oberlin, OH 44074 USA
www.naturalstoneinstitute.org

REV	DATE
0	MAR 2022

STONE URINAL PARTITIONS
(WALL-MOUNTED)

DIMENSION STONE DESIGN MANUAL 2022

DRWG NO: 16-D-7

SCALE:
AS NOTED

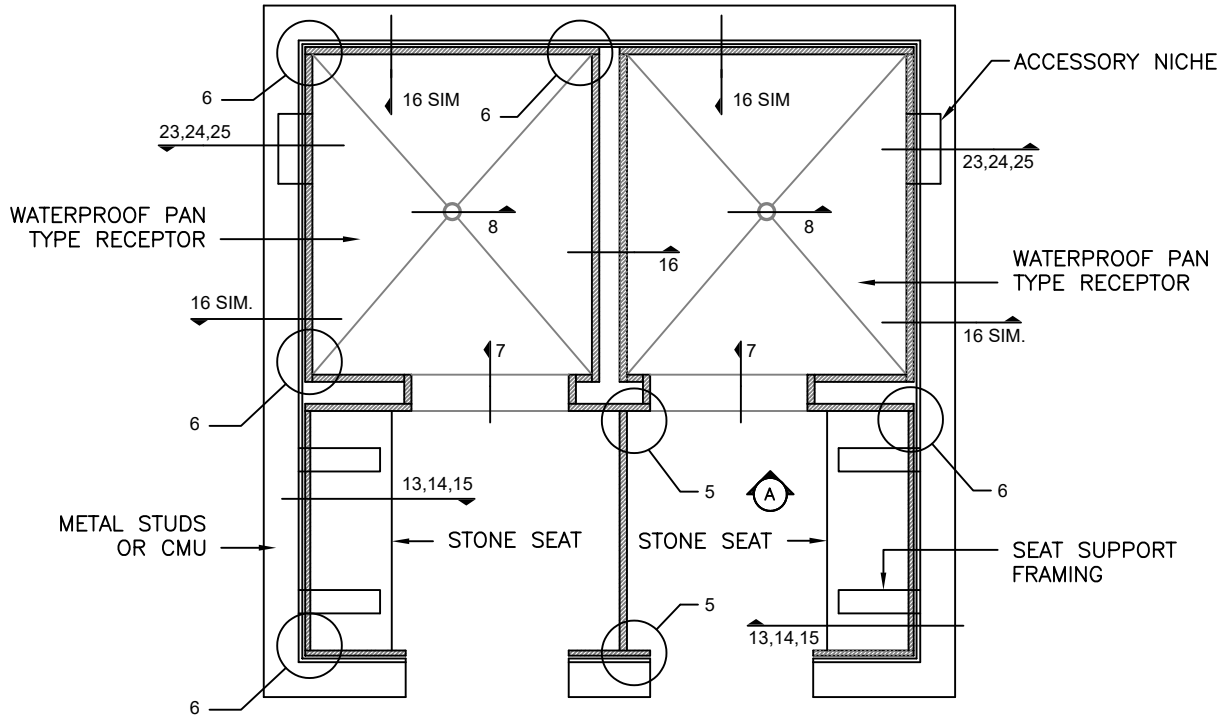

PLAN
WATERPROOF PAN RECEPTOR TYPE

3/8"=1'-0"

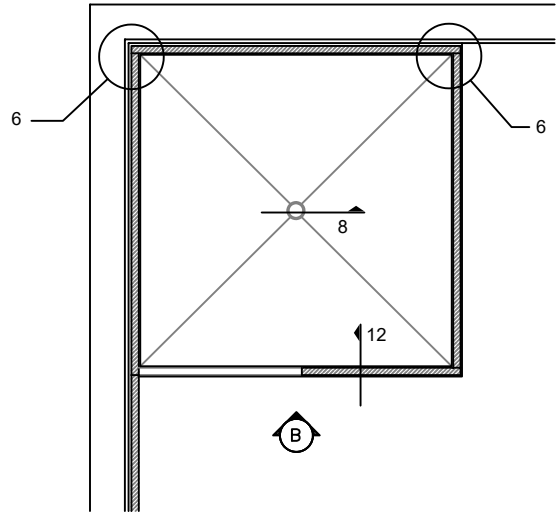

PLAN
PRECAST RECEPTOR TYPE

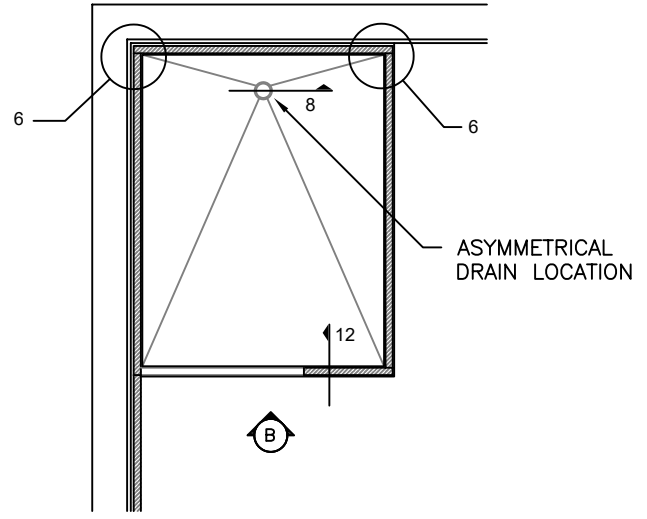

PLAN
PRECAST RECEPTOR TYPE



380 East Lorain Street, Oberlin, OH 44074 USA
www.naturalstoneinstitute.org

REV	DATE
0	MAR 2022

STONE SHOWER PARTITIONS - PLANS

DIMENSION STONE DESIGN MANUAL 2022

DRWG NO: 16-D-8

SCALE:
3/8" = 1'-0"

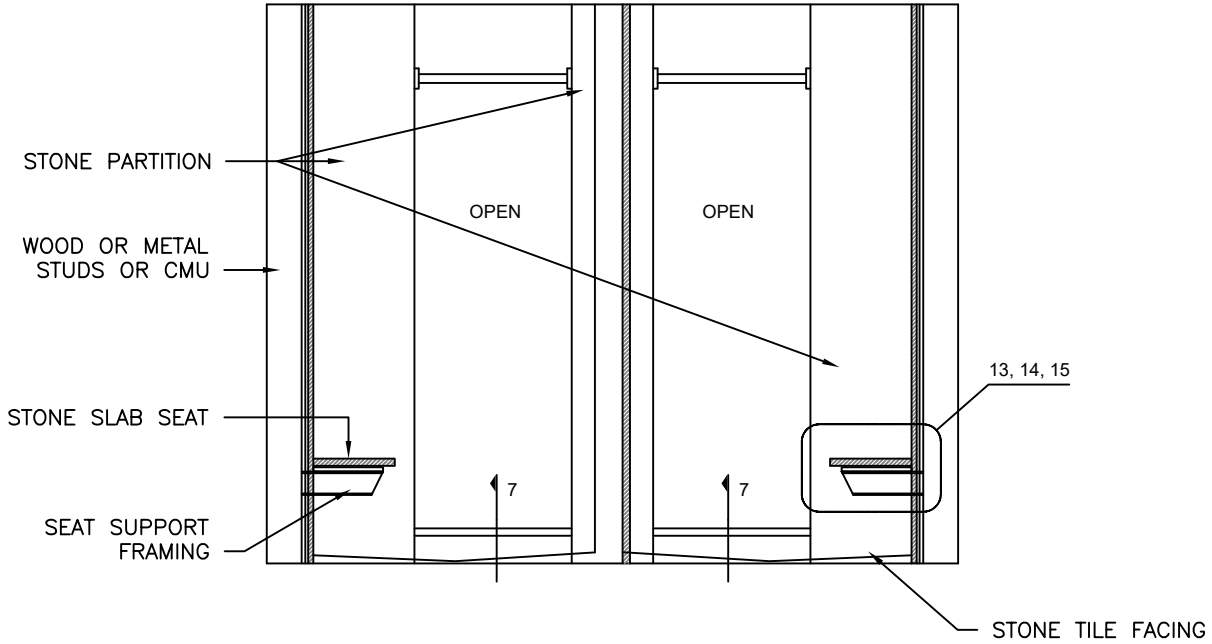

ELEVATION A
WATERPROOF PAN RECEPTOR TYPE

3/8"=1'-0"

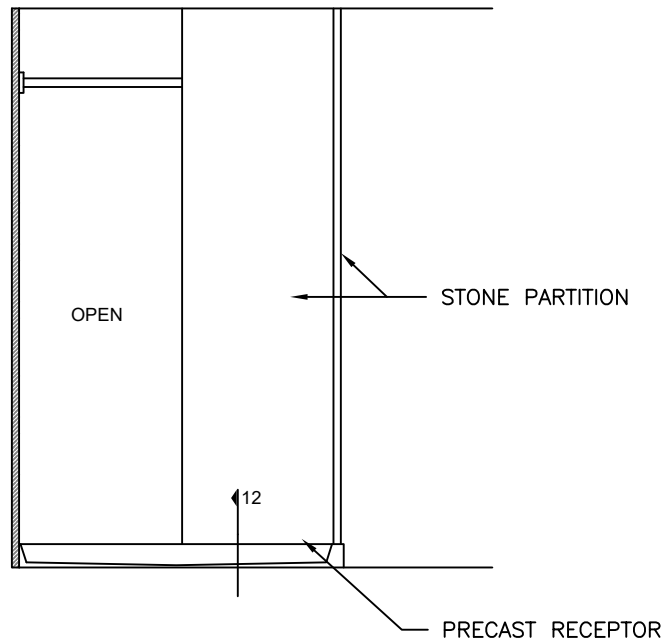

ELEVATION B
PRECAST RECEPTOR TYPE



380 East Lorain Street, Oberlin, OH 44074 USA
www.naturalstoneinstitute.org

REV	DATE
0	MAR 2022

STONE SHOWER PARTITIONS - ELEVATIONS

DIMENSION STONE DESIGN MANUAL 2022

DRWG NO: 16-D-9

SCALE:
3/8" = 1'-0"

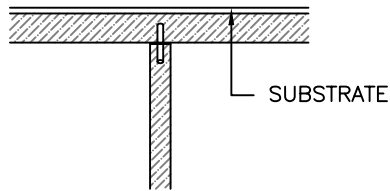

PLAN 1
DOWEL MOUNTED

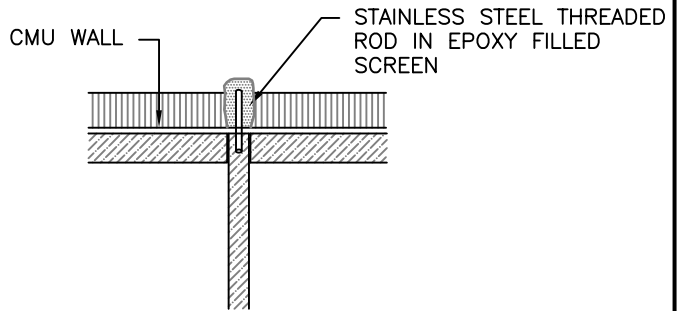

PLAN 2
DOWEL MOUNTED

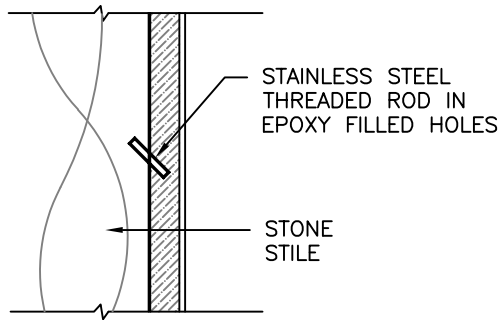

SECTION 3
DOWEL MOUNTED

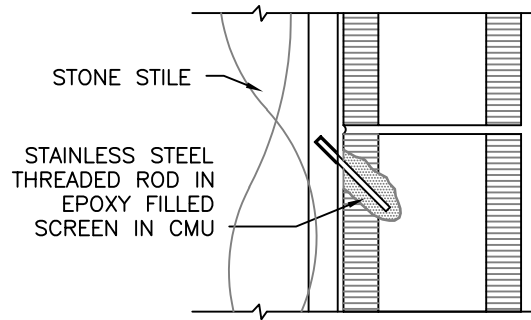

SECTION 4
DOWEL MOUNTED

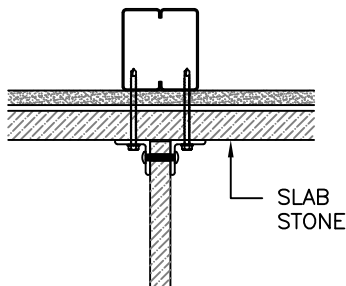

PLAN 5
HARDWARE MOUNTED

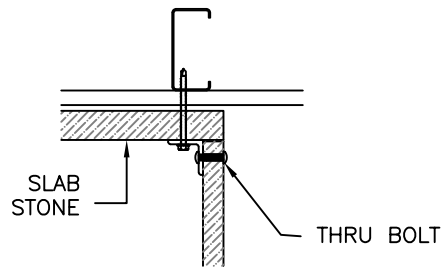

PLAN 6
CORNER



NATURAL
STONE
INSTITUTE

380 East Lorain Street, Oberlin, OH 44074 USA
www.naturalstoneinstitute.org

REV	DATE
0	MAR 2022

STONE SHOWER PARTITIONS

DIMENSION STONE DESIGN MANUAL 2022

DRWG NO: 16-D-10

SCALE:
1½" = 1'-0"

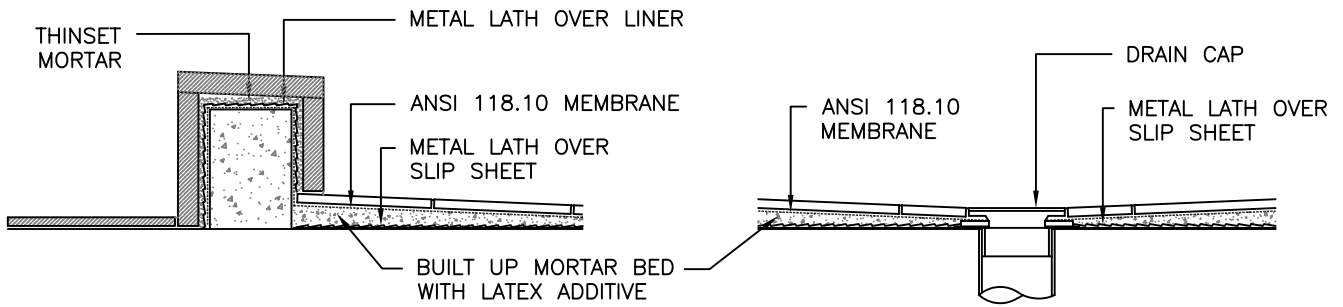

SECTION 7
SHOWER STALL CURB

SECTION 8
SHOWER STALL DRAIN

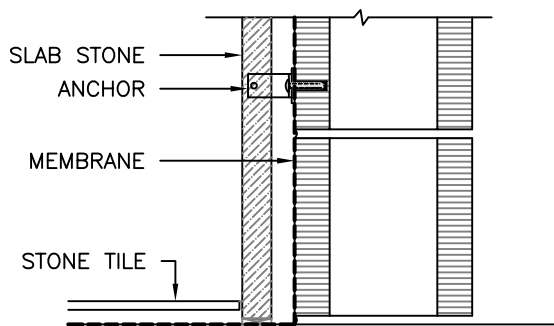

SECTION 9
BOTTOM OF STONE AT CMU

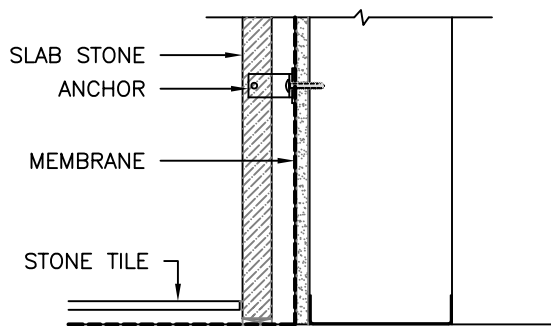

SECTION 10
BOTTOM OF STONE AT METAL STUDS

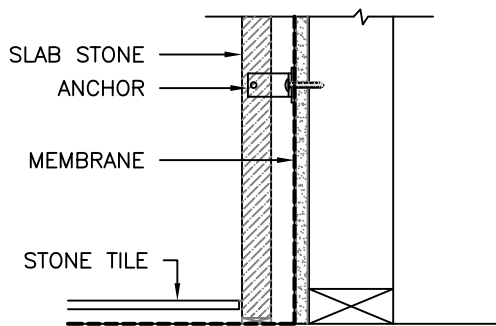

SECTION 11
BOTTOM OF STONE AT WOOD STUDS

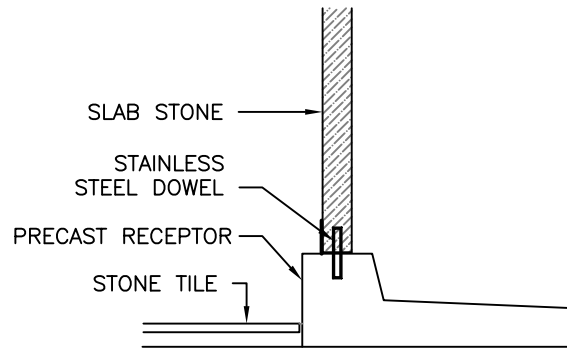

SECTION 12
BOTTOM OF STONE AT PRECAST RECEPTOR

NOTE: REFER TO TCNA HANDBOOK FOR CERAMIC, GLASS, AND STONE TILE INSTALLATION FOR ADDITIOINAL DETAILS



380 East Lorain Street, Oberlin, OH 44074 USA
www.naturalstoneinstitute.org

REV	DATE
0	MAR 2022

STONE SHOWER PARTITIONS

DIMENSION STONE DESIGN MANUAL 2022

DRWG NO: 16-D-11

SCALE:
1½" = 1'-0"

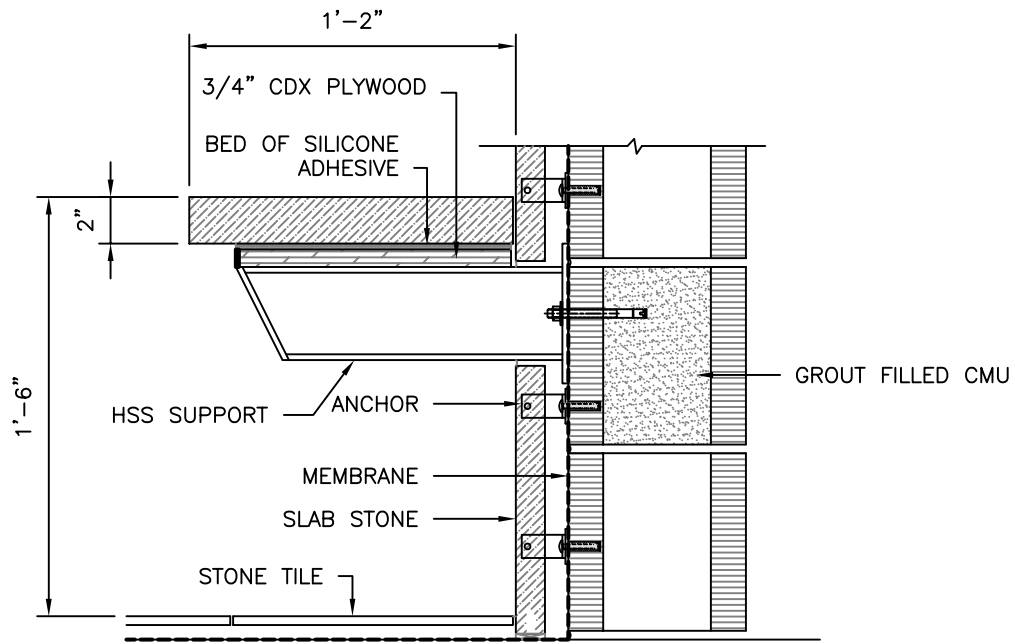

SECTION 13
STONE SEAT AT CMU WALL

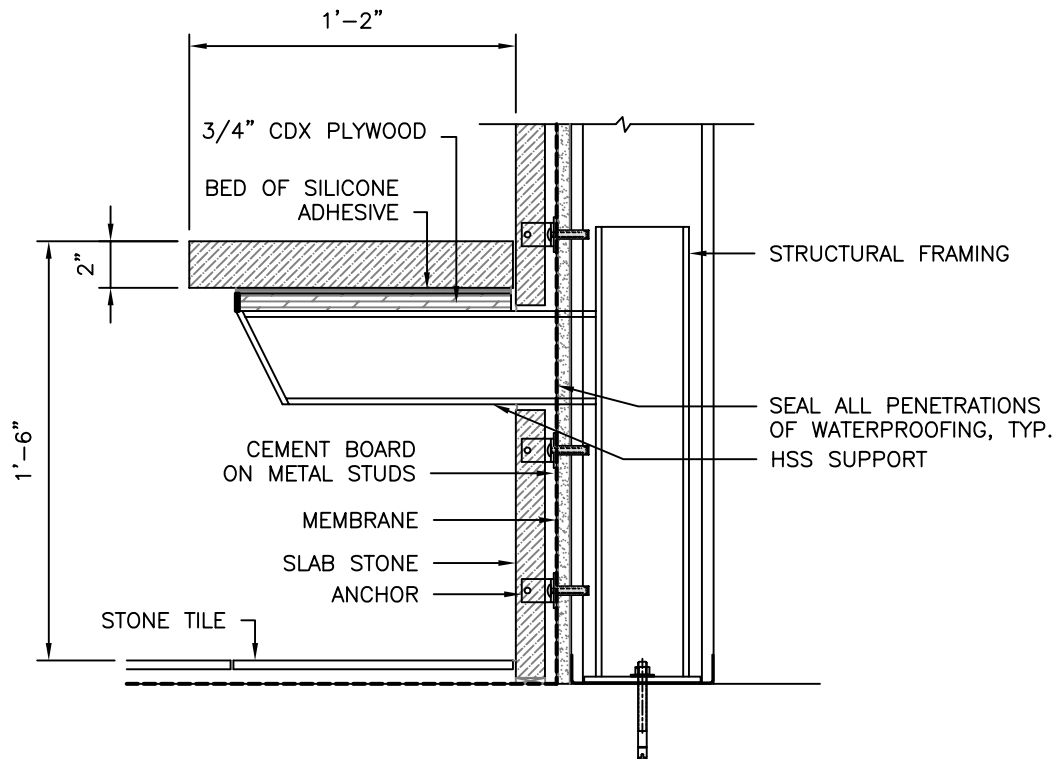

SECTION 14
STONE SEAT AT METAL STUD WALL



380 East Lorain Street, Oberlin, OH 44074 USA
www.naturalstoneinstitute.org

REV	DATE
0	MAR 2022

STONE SHOWER PARTITIONS

DIMENSION STONE DESIGN MANUAL 2022

DRWG NO: 16-D-12

SCALE:
1½" = 1'-0"

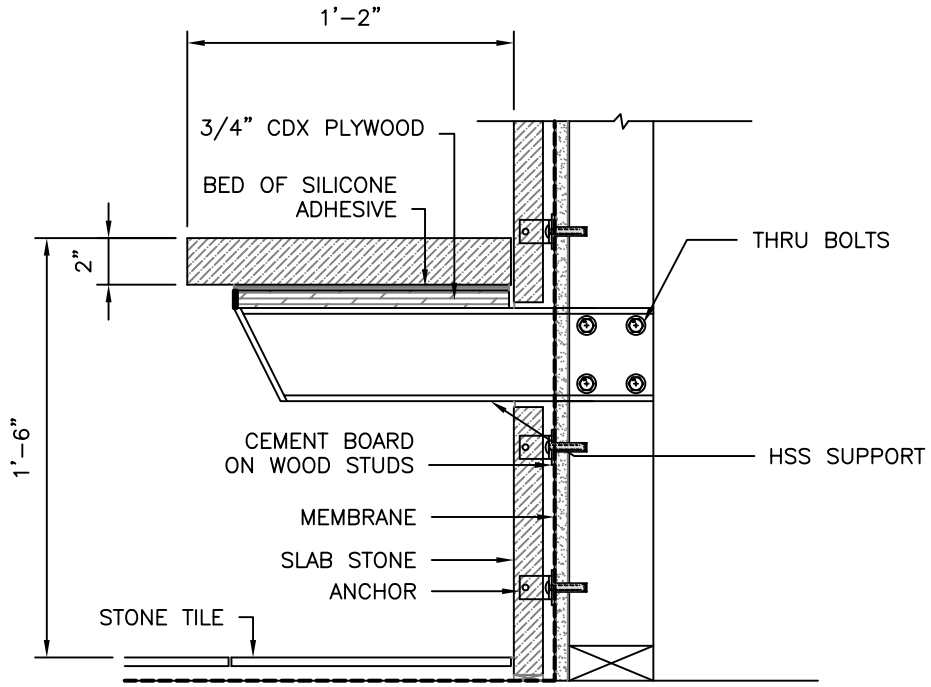

SECTION 15
STONE SEAT AT WOOD STUD WALL

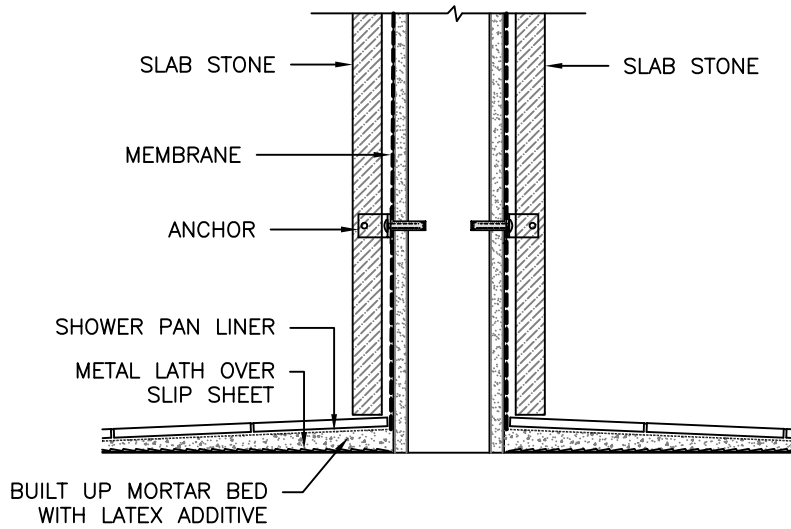

SECTION 16
STONE CLAD SHOWER DIVIDER WALL



380 East Lorain Street, Oberlin, OH 44074 USA
www.naturalstoneinstitute.org

REV	DATE
0	MAR 2022

STONE SHOWER PARTITIONS

DIMENSION STONE DESIGN MANUAL 2022

DRWG NO: 16-D-13

SCALE:
1½" = 1'-0"

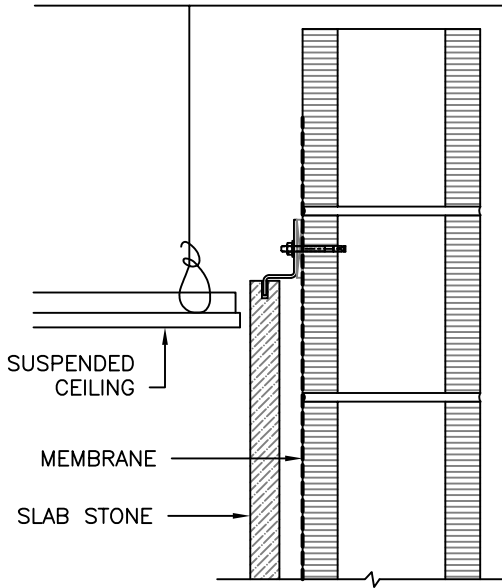

SECTION 17
TOP OF STONE AT CMU

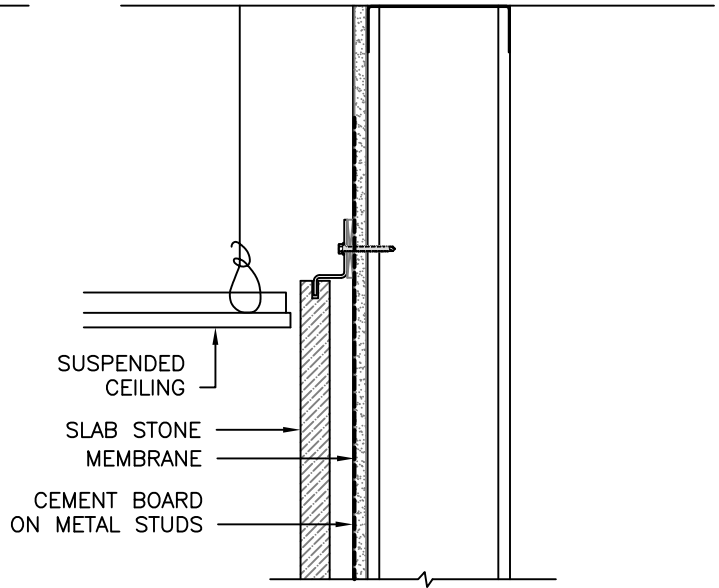

SECTION 18
TOP OF STONE AT METAL STUDS

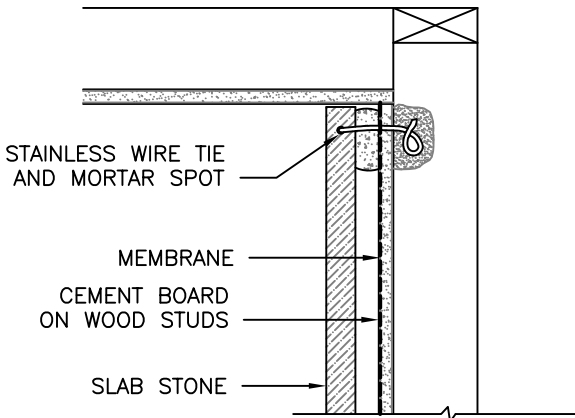

SECTION 19
TOP OF STONE AT WOOD STUDS



380 East Lorain Street, Oberlin, OH 44074 USA
www.naturalstoneinstitute.org

REV	DATE
0	MAR 2022

STONE SHOWER PARTITIONS

DIMENSION STONE DESIGN MANUAL 2022

DRWG NO: 16-D-14

SCALE:
1½" = 1'-0"

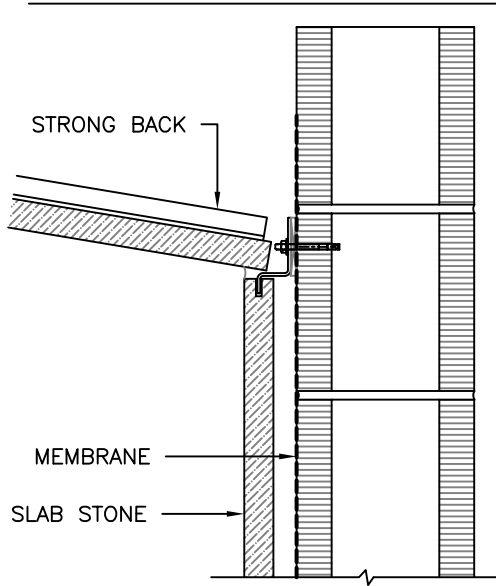

SECTION 20
SLOPING STONE CEILING AT CMU

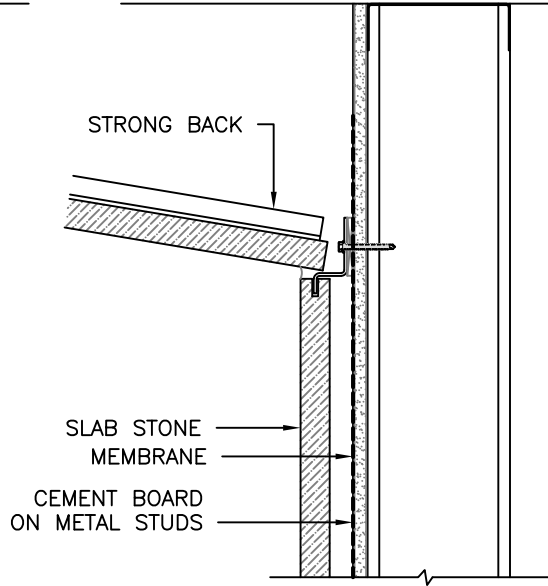

SECTION 21
SLOPING STONE CEILING AT METAL STUDS

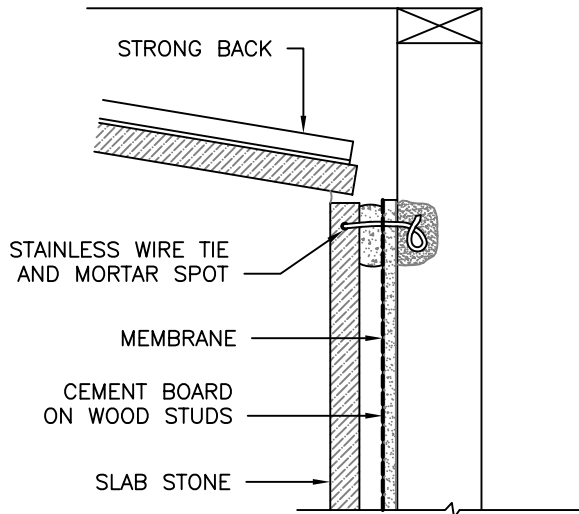

SECTION 22
SLOPING STONE CEILING AT WOOD STUDS



380 East Lorain Street, Oberlin, OH 44074 USA
www.naturalstoneinstitute.org

REV	DATE
0	MAR 2022

STONE SHOWER CELINGS

DIMENSION STONE DESIGN MANUAL 2022

DRWG NO: 16-D-15

SCALE:
1½" = 1'-0"

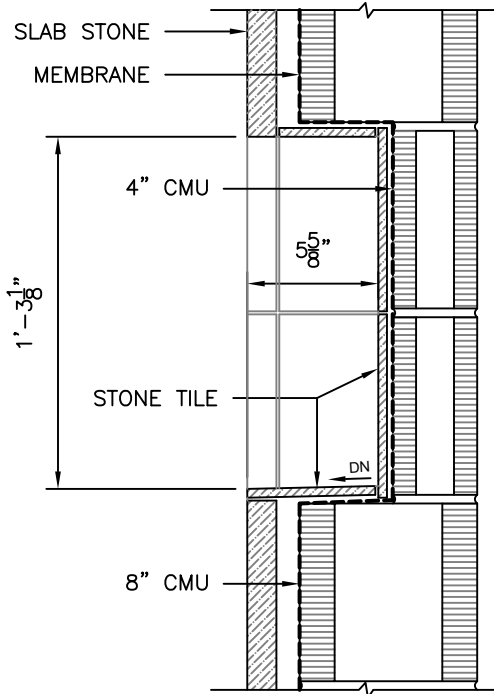

SECTION 23
ACCESSORY NICHE AT CMU

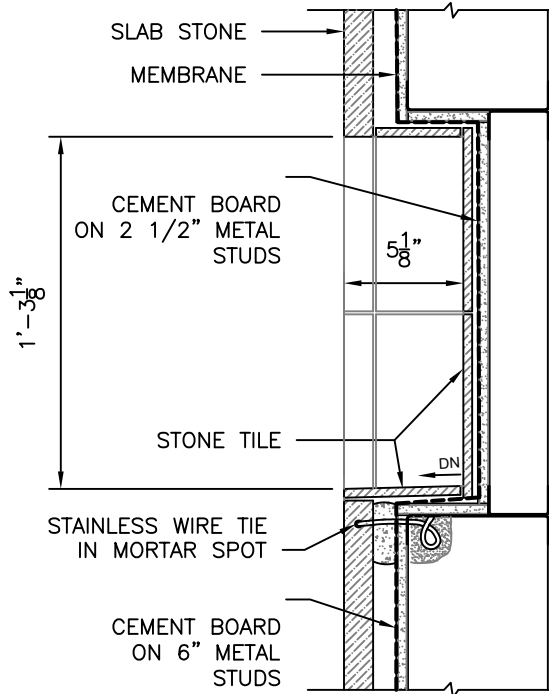

SECTION 24
ACCESSORY NICHE AT METAL STUDS

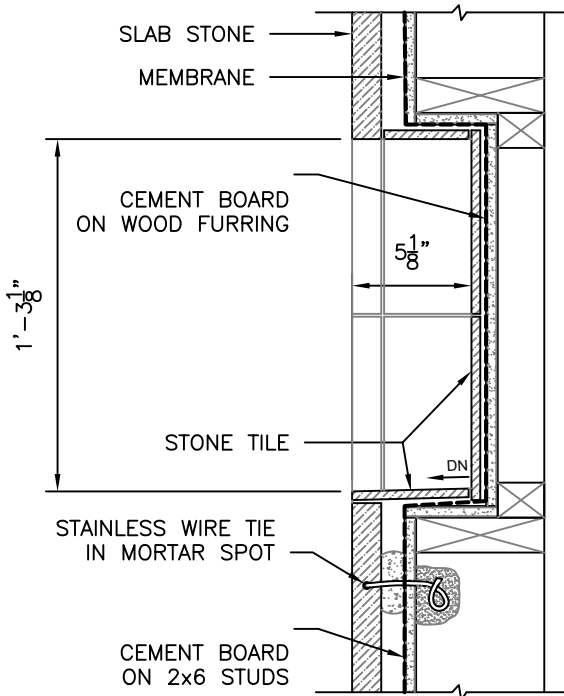

SECTION 25
ACCESSORY NICHE AT WOOD STUDS



380 East Lorain Street, Oberlin, OH 44074 USA
www.naturalstoneinstitute.org

REV	DATE
0	MAR 2022

STONE SHOWER ACCESSORY NICHE

DIMENSION STONE DESIGN MANUAL 2022

DRWG NO: 16-D-16

SCALE:
1½" = 1'-0"

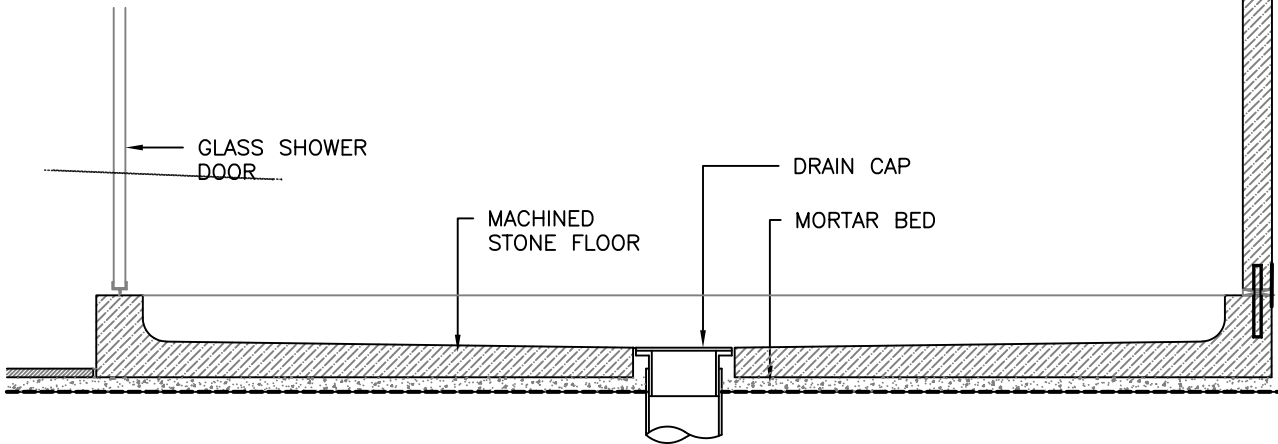

SECTION 26
MACHINED SHOWER FLOOR

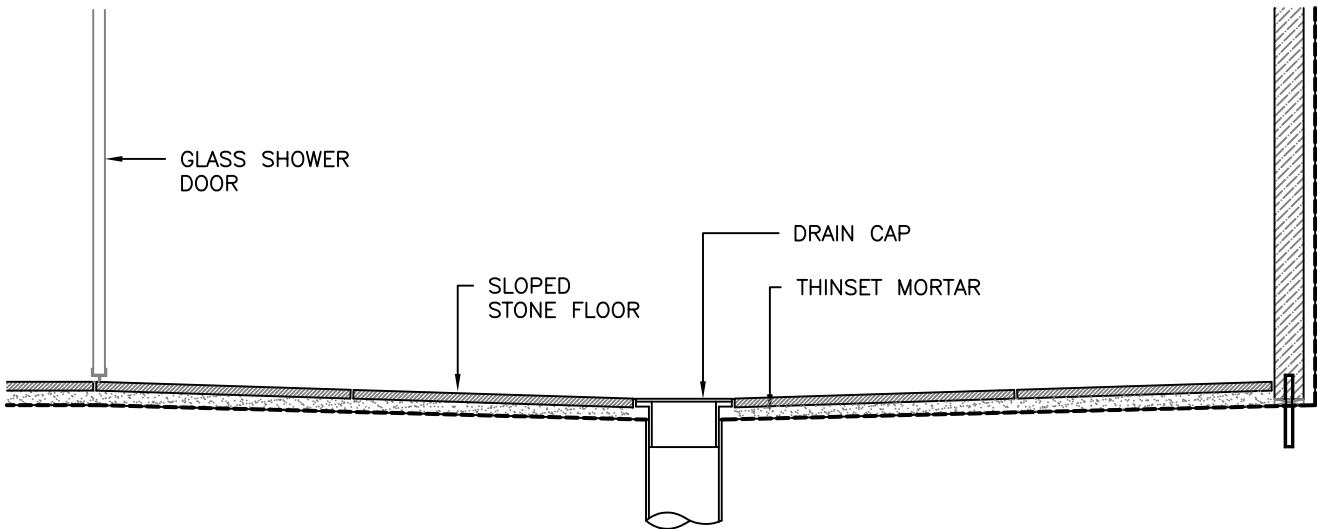

SECTION 27
BARRIER FREE SHOWER FLOOR



380 East Lorain Street, Oberlin, OH 44074 USA
 www.naturalstoneinstitute.org

REV	DATE
0	MAR 2022

STONE SHOWER PARTITIONS

DIMENSION STONE DESIGN MANUAL 2022

DRWG NO: 16-D-17

SCALE:
 1½" = 1'-0"

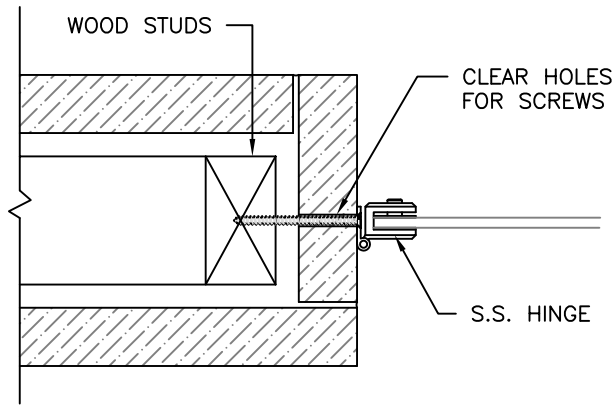

PLAN SECTION 28
JAMB AT SHOWER DOOR HINGE

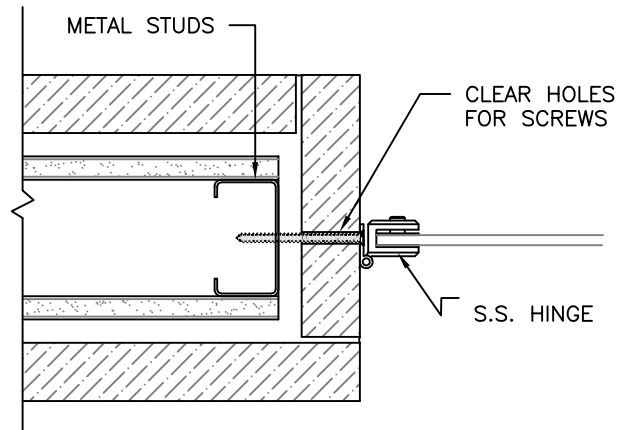

PLAN SECTION 29
JAMB AT SHOWER DOOR HINGE

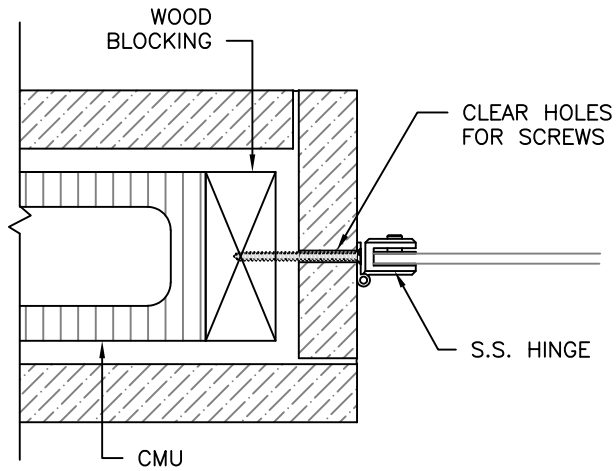

PLAN SECTION 30
JAMB AT SHOWER DOOR HINGE



**NATURAL
 STONE
 INSTITUTE**

380 East Lorain Street, Oberlin, OH 44074 USA
 www.naturalstoneinstitute.org

REV	DATE
0	MAR 2022

STONE SHOWER DOOR JAMBS

DIMENSION STONE DESIGN MANUAL 2022

DRWG NO: 16-D-18

SCALE:
 3" = 1'-0"

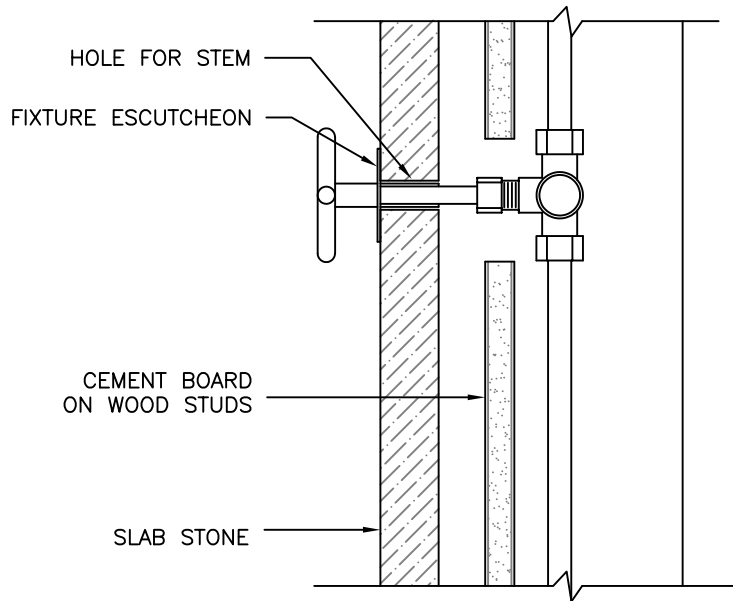

SECTION 31
PLUMBING CONTROL VALVE

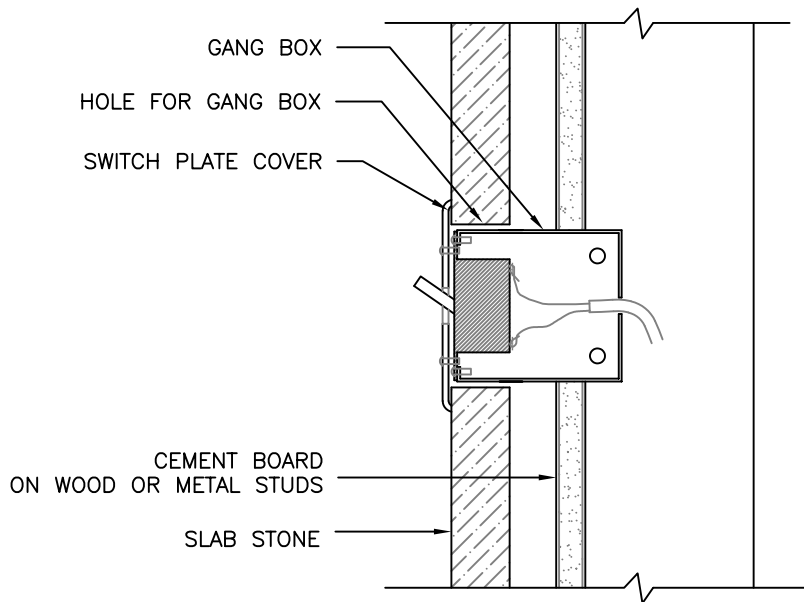

SECTION 32



**NATURAL
STONE
INSTITUTE**

380 East Lorain Street, Oberlin, OH 44074 USA
www.naturalstoneinstitute.org

REV	DATE
0	MAR 2022

STONE SHOWER PARTITIONS

DIMENSION STONE DESIGN MANUAL 2022

DRWG NO: 16-D-19

SCALE:
3" = 1'-0"

NOTES: